

# LUKAS

Because you never get a second chance

## Operating instructions for rescue equipment

CE



### Hydraulic units P650

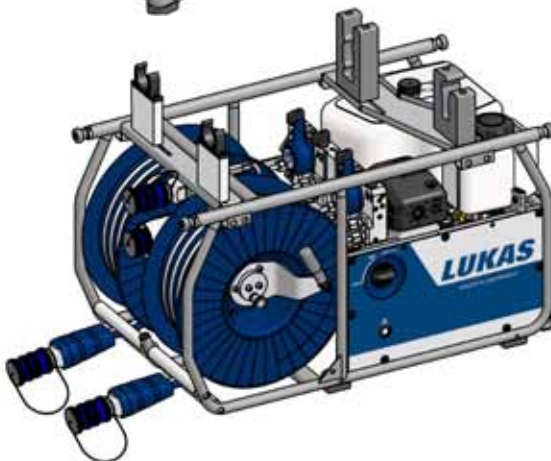

175710085 GB  
Edition 10.2011  
replaces 01.2011

(Translation of the original operating instructions)

# Contents

# Page



1. Hazard classes	5
2. Product safety	6
3. Intended use	10
4. Labelling of the units	11
5. Functional description	11
5.1 <i>General information</i>	11
5.2 <i>Structure of the units</i>	12
5.3 <i>Motor variants</i>	13
5.4 <i>Valve variants</i>	14
5.5 <i>Pumps</i>	15
5.6 <i>Frame with side parts</i>	15
5.7 <i>Connection to the rescue equipment</i>	15
5.8 <i>Hose reels</i>	16
5.9 <i>Carrying handle</i>	16
5.10 <i>Toolholder</i>	16
6. Connection of the hose lines / devices	17
7. Set-up and start-up	19
7.1 <i>Set-up</i>	19
7.2 <i>Start-up</i>	19
8. Operation	20
8.1 <i>Starting the motor/engine</i>	20
8.2 <i>Stopping the motor/engine</i>	21
8.3 <i>Refuelling (combustion engines only)</i>	22
8.4 <i>Controlling the valves</i>	22
8.5 <i>Hose reels</i>	24
8.6 <i>Telescopic carrying handles</i>	26
8.7 <i>Toolholder</i>	27
9. Removing the device / deactivation following operation	32
10. Tests	33
10.1 <i>Recommended inspection intervals</i>	33
10.2 <i>Hydraulic units with combustion engine</i>	34
10.3 <i>Hydraulic units with electric motor</i>	35
10.4 <i>Hose reels</i>	36

11. Maintenance and repair	36
11.1 <i>General information</i>	36
11.2 <i>Maintenance work on the hydraulic unit</i>	37
11.3 <i>Additional maintenance work on units with a combustion engine</i>	39
11.4 <i>Maintenance work on mounted hose reel</i>	43
12. Troubleshooting	46
13. Technical data	53
13.1 <i>Unit</i>	53
13.2 <i>Noise emissions</i>	59
13.3 <i>Sparking plug</i>	59
13.4 <i>Sparking plug socket</i>	59
13.5 <i>Fuel</i>	59
13.6 <i>Engine oil</i>	60
13.7 <i>Hydraulic fluid recommendation</i>	60
13.8 <i>Operating and storage temperature range</i>	60
14. EC Declaration of Conformity	61
15. Notes	63



# 1. Hazard classes

We distinguish between various categories of safety instructions. The table below gives you an overview of the assignment of symbols (pictograms) and key words to the specific hazard and possible consequences.

Pictogram	Damage / injury to	Key word	Definition	Consequences
	People	DANGER!	Immediate danger	Death or major injury
		WARNING!	Potentially dangerous situation	Potential death or major injury
		CAUTION!	Less dangerous situation	Minor or slight injury
	Objects	ATTENTION!	Danger of damage to objects / environment	Damage to the equipment, damage to the environment, damage to surrounding materials
	-	NOTE	Advice for application and other important / useful information and advice	No injury / damage to persons / environment / equipment



Wear helmet with face protection



Wear safety gloves



Wear safety shoes



Proper recycling



Observe principles of environmental protection



Read and observe operating instructions

## 2. Product safety

LUKAS products are developed and manufactured to ensure the best performance and quality when used as intended.

The safety of the operator is the most important consideration in the product design. Moreover, the operating instructions are intended to help the safe use of LUKAS products. The generally applicable legal and other binding regulations pertaining to the prevention of accidents and protection of the environment apply and are to be complied with in addition to the operating instructions.

The device may only be operated by persons with appropriate training in the safety aspects of such equipment – otherwise, there is a danger of injury occurring.

We would like to point out to all users that they should carefully read and adhere to the operating instructions before they use the equipment.

We further recommend that a qualified instructor train you in the use of the product.



**WARNING / CAUTION!**

The operating instructions for the hoses, the accessories and the connected hydraulic equipment must also be observed!





























Even if you have already received instructions on how to use the equipment, you should still read the following safety notes again.





















**WARNING / CAUTION!**

Ensure that the accessories and connected equipment used are suitable for the maximum operating pressure!

	<p>Please ensure that no body parts or clothing get stuck between the visibly moving parts.</p>	<p>Immediately report any changes that occur (including changes in operating behaviour) to the appropriate persons/departments! If necessary, deactivate the device immediately and secure against restart!</p>	
	<p>Wear protective clothing, safety helmet with visor, safety shoes and protective gloves.</p>	<p>Inspect the device for visible defects or damage before and after use</p>	 
 	<p>It is prohibited to work under load if this load is lifted exclusively by hydraulic equipment. If this work is absolutely imperative, additional mechanical supports must be used.</p>	<p>Check all lines, hoses and screwed connections for leaks and externally visible damage, and repair immediately! Escaping hydraulic fluid can cause injuries and fires.</p>	 

	<p>In the event of malfunctions, immediately shut down the equipment and secure it. The malfunction is to be repaired immediately.</p>	<p>Do not carry out any changes (additions or conversions) to the equipment without obtaining prior approval from LUKAS.</p>	
 	<p>Observe all safety and danger notes on the device and in the operating instructions.</p>	<p>All safety and danger notes on the device are to be kept complete and in a legible condition.</p>	
 	<p>Please ensure that all safety covers are present on the equipment and that they are in proper and adequate condition.</p>	<p>Any mode of operation which impairs safety and/or stability of the device is forbidden!</p>	 
 	<p>Safety devices must never be deactivated!</p>	<p>The maximum operating pressure set on the equipment must not be changed!</p>	
	<p>Before the device is switched on/started up, and during its operation, it must be ensured that nobody is endangered by the operation of the device.</p>	<p>Comply with all specified dates or dates specified in the operating instructions pertaining to regular checks / inspections of the equipment.</p>	
 	<p>When working in the proximity of live components and wires, appropriate steps must be taken to avoid current transmission or high-voltage discharge through the device.</p>	<p>Only genuine LUKAS accessories and spare parts are to be used for repairs.</p>	
		<p>When working with this equipment or when transporting it, ensure that you do not get caught up in the hose or cable loops and trip.</p>	
 	<p>The build-up of static charge with the potential consequence of spark formation is to be avoided when handling the device.</p>	<p>When working with combustion engine pumps, never touch the motor and exhaust system, since there is a risk of burning.</p>	
 	<p>Motor pumps may not be used in explosion hazard areas!</p>	<p>Combustion engines must not be used in enclosed spaces, as there is a danger of poisoning and/or asphyxiation!</p>	
 	<p>If fuel for combustion engines is spilled, this fuel must be removed completely before starting the motor.</p>	<p>Filling up during operation of the combustion engine is strictly prohibited!</p>	 

 	<p>Keep combustion engines and their fuel away from ignition sources, as otherwise there is the danger of an explosion.</p>	<p>All damaged electrical components e.g. scorched cables, etc. are to be replaced immediately!</p>	 
 	<p>To avoid the danger of fire when using combustion engines, ensure sufficient ventilation and maintain a safety distance of at least 1 m (39.4 in.) to the walls and other screens.</p>	<p>Damage to electrical components may only be repaired by a qualified electrician in compliance with all applicable national and international safety guidelines and regulations.</p>	
 	<p>Please ensure that the combustion engine pumps are always placed on as flat a surface as possible in order to prevent fuel from leaking.</p>	<p>When setting up the units, it must be ensured that they are not impaired by the influences of extreme temperatures.</p>	
 	<p>The device is filled with hydraulic fluid. These hydraulic fluids can be harmful to your health if swallowed or if their vapours inhaled. Direct contact with the skin is to be avoided for the same reason. Please also note that hydraulic fluids can also have a negative effect on biological systems.</p>	<p>When working with or storing the device, ensure that the function and the safety of the device are not impaired by the effects of extreme external temperatures or that the device is damaged in any way. Please note that the device can also heat up over a long period of use.</p>	
	<p>Ensure adequate lighting when you are working.</p>	<p>Before transporting the device, always ensure that the accessories are positioned such that they cannot cause an accident.</p>	
	<p>Always keep these operating instructions within reach where the device is used.</p>	<p>Ensure the proper disposal of all removed parts, leftover oil, hydraulic fluid and packaging materials.</p>	 

The generally applicable, legal and other binding national and international regulations pertaining to the prevention of accidents and protection of the environment apply and are to be implemented in addition to the operating instructions.

## WARNING / CAUTION / ATTENTION!

The device **is to be used exclusively** for the **purpose stated in the operating instructions (see chapter "Intended Use")**. Any form of use beyond this is **not considered intended use**. The manufacturer / supplier is not liable for any resulting damages. The user bears sole responsibility for such use.

Observance of the operating instructions and compliance with the inspection and maintenance conditions are covered by the definition of intended use.



**Never work when you are overtired or intoxicated!**



### ***WARNING / CAUTION / ATTENTION!***

Should you sustain an injury while working with the hydraulic unit, clean the wound immediately and seek medical attention!



If hydraulic fluid enters your eye, rinse immediately several times with clear, clean water and seek medical attention!

You should also seek medical attention after ingesting hydraulic fluid!

### 3. Intended use

LUKAS hydraulic units are specially designed to supply LUKAS rescue equipment with hydraulic fluid so that this equipment can be used to rescue victims of road, rail or air traffic accidents as well as from buildings.

Their use for supplying pressure / fluid to rescue equipment of other manufacturers is possible, yet requires the technical inspection and approval by LUKAS in each individual case.



#### **WARNING / CAUTION / ATTENTION!**

Always **observe** the safety notes of these operating instructions with regard to place of installation and type of installation!



Type P 650 units manufactured by LUKAS are **not** explosion-proof!

You can obtain accessories and replacement parts for the rescue apparatus from your authorised LUKAS dealer!



#### **CAUTION!**

When selecting a device for connection, remember that the maximum possible useable volume of the hydraulic fluid is limited.

The maximum total volume of hydraulic fluid required by all connected devices must not exceed the maximum possible useable volume of the unit!

Due to the limited useable volume, a maximum of 2 rescue rams can be connected for reasons of safety (only at maximum fill quantity).

Type R424 cylinders are an exception to the rule, however.

**Two of these cylinders should never be coupled and operated simultaneously!**



#### **NOTE:**

Always register your hydraulic unit on the LUKAS Hydraulik GmbH website. This is the only way to guarantee your extended warranty cover.

You must always contact LUKAS or an authorised dealer before using couplings from another manufacturer.

## 4. Labelling of the units

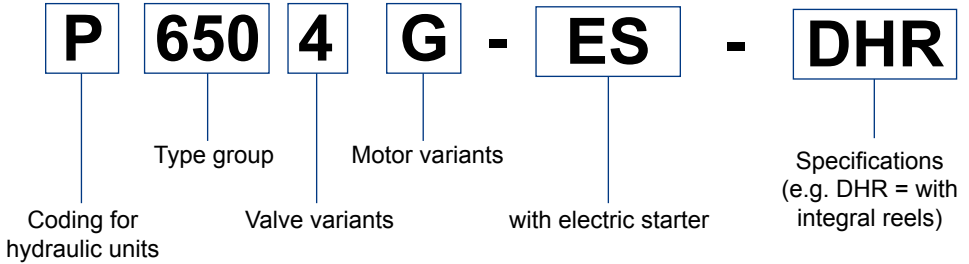

### Valve variants:

S	=	Simultaneous mode
4	=	4POWER mode

### Motor variants:

E	=	Electric motor (operation via mains supply)
G	=	Gasoline engine

## 5. Functional description

### 5.1 General information

The hydraulic pump on all LUKAS hydraulic units is always operated by a combustion engine or electric motor. The pump conveys fluid from the reservoir and builds up hydraulic pressure. The distribution of the fluid is controlled by mounted valves.

Two versions of type P650 unit are available:

1. small frame without reel
2. large frame with mounted reel, Toolholder and carrying handles

The telescopic carrying handles are an optional accessory for the first version and can always be retrofitted.



#### **NOTE:**

A hose reel is only included with the second version and **cannot** be retrofitted at a later date!

## 5.2 Structure of the units

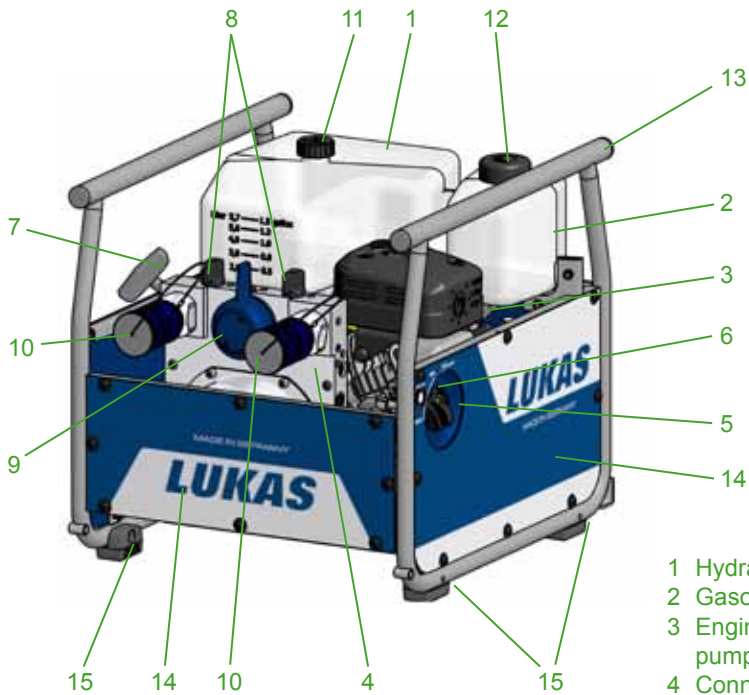

- 1 Hydraulic fluid reservoir
- 2 Gasoline tank
- 3 Engine with hydraulic pump

- 4 Connecting block with control valves

- 5 Engine switch
- 6 Electric starter button

- 7 Pull cord starter

- 8 Valve control lever

- 9 "TURBO" control lever

- 10 Mono-couplings

- 11 Hydraulic fluid fill cap

- 12 Gasoline fill cap

- 13 Frame

- 14 Side panel

- 15 Rubber buffer

- 16 ON/OFF switch for electric motor

- 17 Telescopic carrying handle  
(also optionally available for retrofitting)

- 18 Hose reel

- 19 Crank handle (hose reel)

- 20 Lock (hose reel)

- 21 Hose guide

- 22 Toolholder

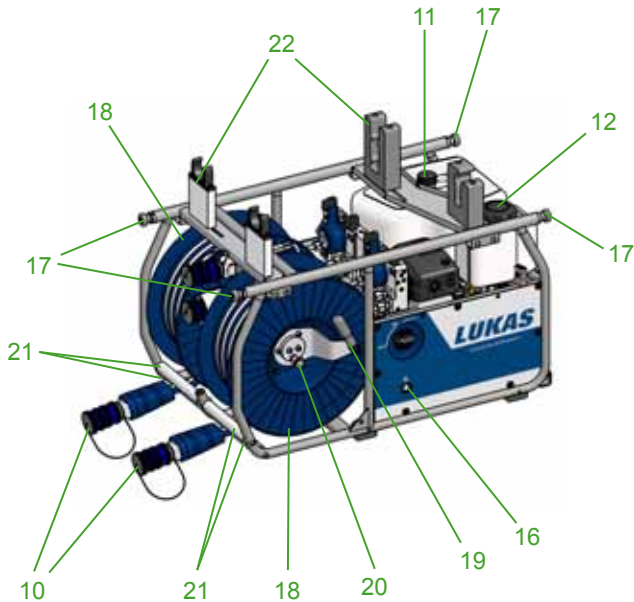

## 5.3 Motor variants



### **WARNING / CAUTION / ATTENTION!**

For all motor variants, also comply with the separate operating instructions of each motor manufacturer.

### 5.3.1 Electric motor

These hydraulic units are equipped with an electric motor. The electric motor is driven by electricity from the mains supply or by electricity produced by generators. In the case of operation with generators, make sure that voltage fluctuations do not occur, as these have a direct influence on the pumping capacity and stability of the hydraulic unit.

The possible operating voltage, the current frequency and the required intensity of current can be found in the chapter entitled „Technical data“.



#### **NOTE:**

Using an extremely long electrical connection cable may reduce the output resistance and the power supply to the motor. The performance of the motor will be affected as a result.

### 5.3.2 Gasoline engine

These hydraulic units are equipped with a combustion engine driven by the fuel "gasoline / gasoline".

Units can be fitted with both an electric starter and a pull cord starter, or a pull cord starter only. It is only possible to determine the unit version from the item number and unit name or the designation printed on the unit.

The integral generator charges the starter battery automatically while the engine is operating.



#### **NOTE:**

Not all the technical details of the engine installed in LUKAS units correspond to the engine described in the separate operating instructions provided by the manufacturer. Components such as the gasoline tank have been modified to guarantee the safety of the overall hydraulic unit because the unit is used for rescue operations.

However, it is important that you observe all safety regulations and operating, maintenance and storage instructions included in the separate manual accompanying the engine without fail because they are unaffected by any adaptations made by LUKAS.

If the battery discharges completely after a period of inactivity, you must start the unit using the cord pull starter and allow the unit to operate until almost a complete tank of fuel has been consumed. The battery will then be fully charged.

If the battery is still not charged after the unit consumes a full tank of fuel, the causes may include the following:

- the contacts (connector) have come loose and must be connected again.
- the battery is defective and must be replaced.
- the generator or engine is damaged. In this case, contact LUKAS customer service directly.

## 5.4 Valve variants

The valves are always permanently installed in a connecting block. This block is integrated directly in the hydraulic unit. Both hose lines (pressure and return) are always connected to the connecting block. The units are fitted either with a SIMO or a 4POWER connecting block.

Both connecting blocks also have a TURBO function.

More specifically, this means that there are always 2 device connections linked internally to one another. A shift lever gives you the option of supplying hydraulic fluid to both connected devices simultaneously or supplying double the quantity to one device (= TURBO function). Supplying double the quantity of fluid increases the operating speed of the connected device.

The hoses and devices are always connected to the connecting block via mono-couplings. On units with a hose reel, only the connection hoses between the hose reel and connecting block are screwed in position.



### **CAUTION!**

When operating several pieces of rescue equipment with one unit, ensure that the usable volume of hydraulic fluid in the reservoir is greater than the maximum possible operating fluid volume of all connected rescue equipment.

### 5.4.1 "Simultaneous mode" (SIMO) control valve

This valve enables the connection of two dual-acting hydraulic devices. The valve allows you to operate two devices simultaneously and independently of one another or supply a larger quantity of hydraulic fluid to one device. Supplying a larger quantity of hydraulic fluid increases the operating speed of the relevant device.

There are three switches available. The two smaller switches can be used to depressurise the individual connections. The large switch is responsible for controlling the TURBO function.

### 5.4.2 "4POWER mode" control valve

This valve enables the connection of four dual-acting hydraulic devices. The valve allows you to operate four devices simultaneously and independently of one another or supply a larger quantity of hydraulic fluid to a maximum of two devices. Supplying a larger quantity of hydraulic fluid increases the operating speed of the relevant devices. The TURBO function can only be connected between the points either side of the large switch because the device connections are linked internally.

There are six switches available. The four smaller switches can be used to depressurise the individual connections. The large switches are responsible for controlling the TURBO function.

The switches and connections are labelled to make them easier to assign to one another.

## 5.5 Pumps

LUKAS hydraulic units are equipped with a double-flow or four-flow pump depending on the type. The pumps are permanently connected to the connecting block.

Double-flow pump for operation with SIMO valve

Four-flow pump for operation with 4POWER valve

The pumps used are always equipped with two pressure levels for each pump capacity, one low-pressure and one high-pressure level.

Low-pressure level (LP) = up to 14 MPa\*

\*) 1 MPa = 10 bar

High-pressure level (HP)= up to 70 MPa\*

The changeover from low pressure to high pressure is carried out automatically in the pump. The maximum pressure is limited by a pressure limiting valve.



### **WARNING / CAUTION / ATTENTION!**

For reasons of safety, the pressure set on this valve **must not** be adjusted (without direct authorisation from LUKAS)!



## 5.6 Frame with side parts

A surrounding frame is fitted to all the hydraulic units described here, without exception. The frame and the side parts are designed to protect the unit from external influences (e.g. dirt, damage, etc.), to attach accessories (e.g. Toolholders) and as a means of transporting the unit by the frame itself or the optional carrying handles. The starter equipment and accelerator cable regulator on units with a combustion engine are mounted on the frame or side parts.

## 5.7 Connection to the rescue equipment

Connection with the rescue equipment is via extension hose pairs or hose reels. These are available in various lengths and coloured bend protections.

Different colours distinguish the individual hose lines in a hose pair.

*(For specific details, please consult the LUKAS range of accessories or contact your LUKAS dealer).*

## 5.8 Hose reels

The hose reels were designed to store extension hose pairs leading between the hydraulic supply and the working equipment (hose pairs are included in the delivery as standard). The extension hose pairs are connected to the hose reels and rolled onto the drums.

A hose reel with extension hose pairs can cover long distances between the hydraulic supply and the working equipment, allowing you to keep the hydraulic unit on a vehicle, for example. The possibility of rolling up and unrolling the hose allows you to adapt the hose length accordingly and reduce the amount of unnecessary or potentially dangerous excess hose lying on the ground.

The extension hose pairs are easier to transport and store when fully rolled up.

Moreover, the hose reels on type P650 units are equipped with a hose guide that facilitates easier rolling up and unrolling.

The unit is connected to the working equipment via couplings.



### **CAUTION!**

In order to avoid potential losses in pressure, the length of the extension hose lines must not exceed 30 m!



### **NOTE:**

Only 2 of the 4 connections can be connected to the hose reel on type P 650 4G units.

There are 2 coupling connections located between the two reel drums for the remaining two connections. The lower of the two connections is extendable to allow easier coupling. It also engages easily in the end positions.

The switches and connections are labelled to make them easier to assign to one another.

## 5.9 Carrying handle

Type P650 LUKAS hydraulic units without a hose reel can be fitted with optional carrying handles. The scope of delivery of units with a hose reel already includes handles.

The P650 can be transported more ergonomically using the carrying handles.

## 5.10 Toolholder

Type P650 LUKAS hydraulic units with a hose reel are fitted with a Toolholder.

The Toolholder is usually designed to attach a SP310 spreader and a type S5xx cutter.

Needless to say, it is possible to adapt the mount to accommodate all LUKAS cutters and spreaders as well as modify it at a later date.

The Toolholder allows you to transport a unit with devices still attached.

You no longer have to detach and store devices separately after use. You only have to wind the hose lines onto the reels and position the devices on the Toolholder again.

Devices secured to the unit do not pose a risk during transport.

## 6. Connection of the hose lines / devices



### **CAUTION!**

When connecting the hose lines / devices, always ensure that the connection components are not soiled. Clean beforehand if necessary!



### **WARNING / CAUTION / ATTENTION!**

Before connecting equipment, make sure that **all the components used** are suitable for the **maximum operating pressure of the hydraulic unit!** In cases of doubt, you **must consult LUKAS** directly before connecting the equipment!



The hose lines / devices are connected to the hydraulic pump or hose reel via mono-coupling halves (male and female) without any risk of confusion.

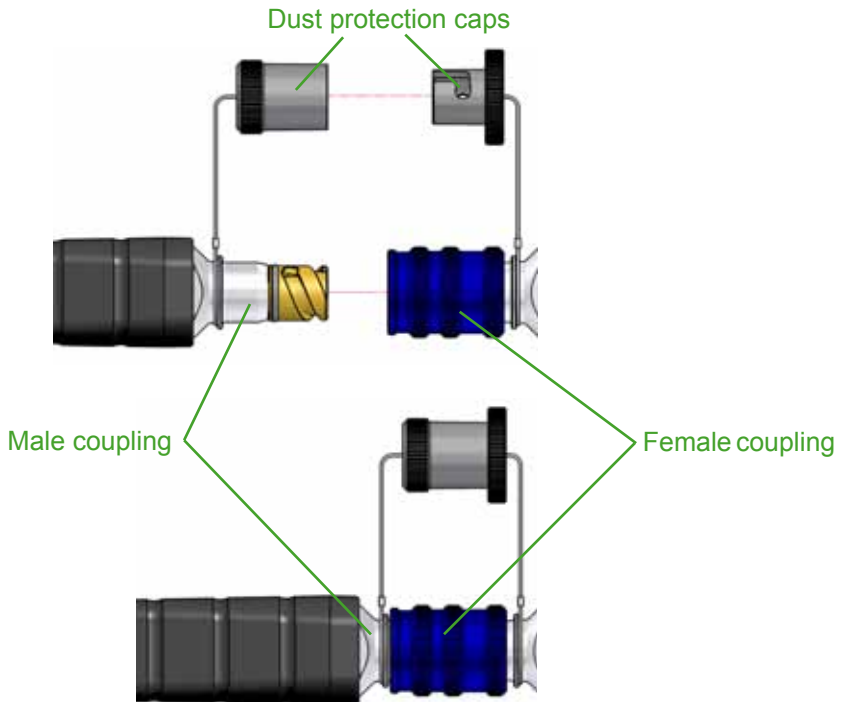

Before coupling, remove the dust protection caps, then connect male and female couplings and turn the locking sleeve of the female coupling in direction "1" until the locking sleeve latches. The connection has now been made and locked. Decoupling is accomplished by turning the locking sleeve in direction "0".

Coupling of the hose lines when under pressure is also possible, assuming the connected equipment is not turned on.



**NOTE:**

We **recommend** connecting the coupling halves in a **depressurised** state when working in areas with low ambient temperature and using extension hose assemblies / hose reels, otherwise the coupling may require the application of a great deal of force.

For dust protection, the supplied dust caps must be refitted.

**Fitting the dust protection caps:**

The "A" dust protection caps have two external grooves "B". The dust protection caps must be inserted in the female coupling in such a way that the grooves can be guided over the "C" pins. Screw the dust protection caps to the limit stop to fix in the female couplings.

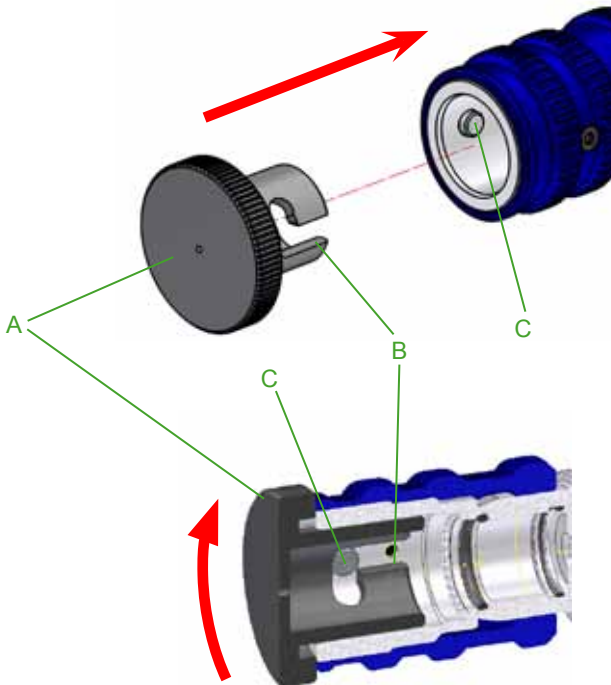

## 7. Set-up and start-up

### 7.1 Set-up



#### **WARNING / CAUTION / ATTENTION!**



Combustion engine units and electrical units must not be used in a potentially explosive situation (danger of the formation of sparks). Units with combustion engines must not be used in enclosed spaces, as there is a danger of poisoning and/or asphyxiation!

The unit is to be set up in a suitable location (safe location / flat surface / sufficient distance from vehicles, loads, sources of ignition, etc.).

LUKAS units work perfectly at an angle of up to 20°. However, in order to guarantee maximum safety and fluid withdrawal, they should be operated in as horizontal a position as possible.

### 7.2 Start-up



#### **NOTE:**

Before commissioning the unit for the first time or after longer periods of inactivity, the starter battery must be connected and the engine oil checked (units with a combustion engine)! Replenish the engine oil if necessary!  
LUKAS units are delivered without engine oil for reasons of safety!

*Please proceed as follows:*

1. First of all, check the fluid levels in the unit.

The translucent reservoirs provide a good view of the fluid levels in the unit. The reservoirs have marks that indicate the minimum and maximum levels. If possible, the hydraulic unit should be positioned on a level surface when the fluid levels are read and the reservoirs filled.



#### **CAUTION!**

Always fill fuel and hydraulic fluid into the correct reservoir otherwise the unit may sustain damage!

2. On hydraulic units with an electric motor, connect the plug to the power supply at this point.
3. Then vent the hydraulic unit. Set all levers on the control valves to the neutral position (see chapter "Operation"). The actual venting is carried out in the units in a different manner, depending on the drive motor:
  - a) *Gasoline engine:*
    - Detach all connectors from the sparking plugs (on the back of the unit).
    - Slowly turn the engine over with the starter rope several times.
    - Then replace the sparking plug connector.
  - b) *Electric motor (mains power operation):*
    - Switch the motor on and then off again after approx. 10 seconds, repeat this procedure several times. (Before switching back on, the motor must be at a standstill!)

This procedure means that the pump can slowly draw fluid in and be well vented. The hydraulic fluid reservoir is equipped with automatic venting, which means no further venting measures are required.

4. Check the fluid levels in the reservoirs again. If necessary, top up the fluid.
5. To conclude, you can now connect the extension hoses and/or hose reels (unless already connected to the unit) and/or couple the rescue equipment.

## 8. Operation



### **CAUTION!**

The control levers on the hydraulic unit must be shifted to neutral position **before the motor/engine is started** to prevent connected hydraulic equipment from moving unexpectedly.

Levers on units with a Toolholder should only be shifted back after you have removed the devices from the mount and intend to start work.

### 8.1 Starting the motor/engine

#### 8.1.1 Gasoline engines

Before starting the combustion engines, check that the fuel tank is full and that the engine oil level is within the permitted tolerances. If necessary, top up the relevant fluid.

#### Starting procedure:

1. Set the engine switch to the "CHOKE" position (N) (if the engine is already warm or the ambient temperature is high, start the engine with the switch in the "ON" position.)
2. Starting with electric starter:  
Press the starter button



#### Starting with pull cord starter:

Slowly pull the handle on the pull cord starter beyond the compression point (resistance is felt). Allow to return to the starting position and pull again quickly all the way out.



### **NOTE:**

If the engine refuses to start after several attempts, repeat the procedure described above with the engine switch set to the "ON" position.

3. When the engine starts, keep hold of the handle on the pull cord starter and allow it to return to its starting position.
4. Allow the engine to warm up for 20 to 30 seconds and then set the engine switch to the "ON" position (if previously set to "CHOKE").

### 8.1.2 Electric motors

Before starting the electric motors, check that all electrical connections and cables are in proper order. First of all, connect the power cable (for motors with power supply) to the supply socket.

The motor is started by pressing the ON/OFF switch on the side of the unit. The ring around the switch lights up when the unit is switched on.



#### **CAUTION!**

Electric motors draw a brief, very high starting current. When using a generator, you should therefore check to see that it can supply the relevant current strength. *The power supply must be protected by a 25 A fuse at least.*

## 8.2 Stopping the motor/engine

### 8.2.1 Gasoline engines

The engine on the unit stops automatically when the fuel tank is empty. However, you should stop the machine and refuel before this happens.

The following procedure stops the engine manually:

#### Stopping procedure:

1. Make sure that all connected rescue devices are in base position (starting position).
2. Set the levers on the control valves to neutral position (depressurised).
3. Set the engine switch to the "OFF" position.



#### **WARNING / CAUTION!**

Never touch the hot motor / engine parts: this could result in severe burns!

### 8.2.2 Electric motors

Set the levers on the control valves to neutral position (depressurised).

Pressing the ON/OFF switch on the side of the unit switches the engine off again. The illuminated ring around the switch goes out.

When the engine is switched off, the connected hydraulic pump stops delivering.

## 8.3 Refuelling (*combustion engines only*)

The engine must be switched off during refuelling!

### **Procedure:**

1. Open the fill cap on the fuel tank.
2. Fill the tank with fuel up to the maximum mark.



### **WARNING / CAUTION / ATTENTION!**

Make sure you do not spill any fuel! If fuel comes into contact with hot engine components, in particular, there is a risk it may ignite and start a fire!



If fuel is spilled by accident, it must be cleaned up immediately using a suitable absorbent cloth. Make sure you do not burn yourself on hot engine components! The cloth used to absorb the spilled fuel must then be washed and disposed of according to applicable regulations and guidelines!

3. Replace the fill cap on the fuel tank again correctly.

## 8.4 Controlling the valves



### **CAUTION!**

The control levers on the hydraulic unit must be shifted to neutral position (depressurised) **before the motor/engine is started** to prevent connected hydraulic equipment from moving unexpectedly.

### 8.4.1 "Simultaneous mode" (SIMO) control valve

Three levers are located on the connecting block of this valve.

Each of the two small levers is assigned to a pressure port. Actuating the respective lever regulates the pressure in the corresponding pressure hose ("↓⊕") or depressurises the connection ("✖⊕").



There is also a large lever that controls the "TURBO" function. Shifting the lever to the relevant position allows you to supply double the quantity of hydraulic fluid to one of the two connections.

In order to activate the "TURBO" function, both connections must be pressurised. The "TURBO" function is activated by turning the large lever towards the connection that requires double the fluid quantity.



**NOTE:**

All shift levers must always be moved all the way to their end position.



**8.4.2 "4POWER mode" control valve**

Six levers are located on the connecting block of this valve.

Each of the four small levers is assigned to a pressure port. Actuating the respective lever regulates the pressure in the corresponding pressure hose ("↓⊕") or depressurises the connection ("✕⊕").



There are also two large levers that control the "TURBO" function. Shifting the lever to the relevant position allows you to supply double the quantity of hydraulic fluid to one of the two connections either side of the lever.

In order to activate the "TURBO" function, both connections must be pressurised. The "TURBO" function is activated by turning the large lever towards the connection that requires double the fluid quantity.



**NOTE:**

All shift levers must always be moved all the way to their end position.

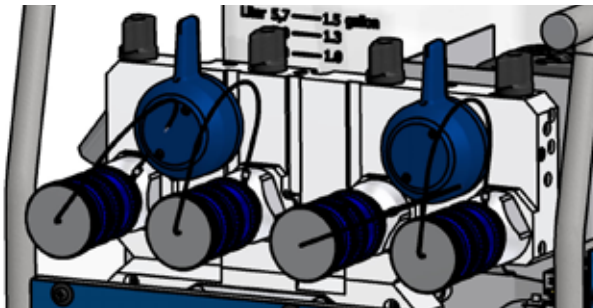

## 8.5 Hose reels

### 8.5.1 Locking brake

The locking brake is designed to prevent extension hose pairs from unrolling during transportation! Pull and turn knob "A" through 90° to release the locking brake.

To apply the locking brake, turn knob "A" through approx. 90° until it engages automatically.

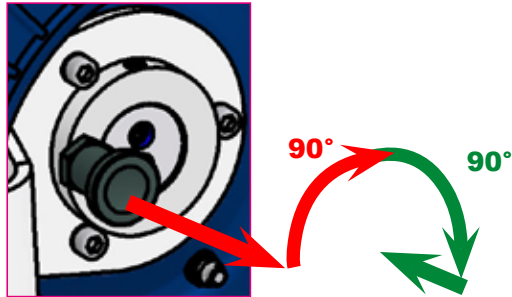

### 8.5.2 Crank handle

The crank handle should make the hose easier to roll up!

To use the crank handle, pull lever "B", fold outwards through 90° and release so that it engages.

To fold away the crank handle, pull lever "B", fold inwards through 90° and release so that it engages.



### 8.5.3 Unrolling

Pull the extension hose pair until the required length has unrolled from the hose reel.



#### **CAUTION!**

Release the locking brake on the hose reel beforehand to avoid damaging the reel and the pair of hoses!

When unrolling the hoses, make sure that nobody is standing within the movement range of the crank handle.

## 8.5.4 Rolling up



### **NOTE:**

We recommend using the crank handle to roll up the hoses!

- Fold out the crank handle.
- Check that the locking brake on the double hose reels is released.
- Align the reels so that the unrolled hoses are rolled up in a straight line. You will find that the hoses roll up more easily.
- You can now roll up the pair of extension hoses by turning the crank handle.

*Make sure that the direction of rotation is always the same as shown in the illustration!*

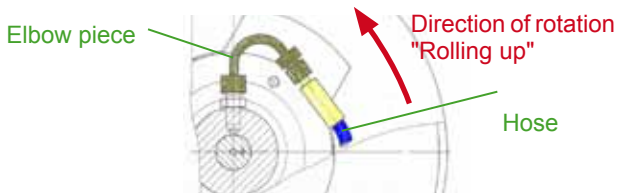

*Make sure that the pair of extension hoses is always rolled up correctly onto the hose drum.*

*We recommend guiding the pair of extension hoses with your hand during the rolling process. You must always guide the pair of hoses in a perpendicular direction to the reel axis because of the hose guide attached to the hose reel.*

- You must then apply the locking brake on the double hose reels.



### **CAUTION!**

The bend protection on the hoses should only rest lightly on the hose guide when the hose is rolled up completely.

However, if the hose line is rolled up so far that the bend protection is pressed up against the hose guide, the following could occur:

- The hose material is stretched and the hose damaged, possibly beyond repair.
- The couplings, bend protection and hoses may be damaged during transportation or storage.

## 8.6 Telescopic carrying handles

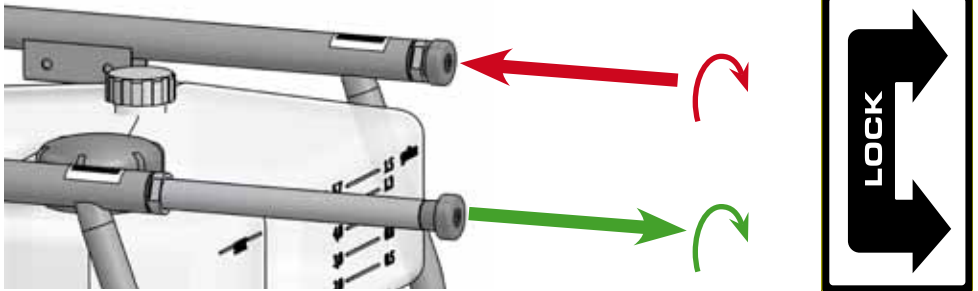

Units with a hose reel are fitted with carrying handles. Units without a hose reel can be retrofitted with handles if required. The handles should be used to transport the P650.

The telescopic carrying handles are screwed directly to the frame. The blanking plugs must be removed before the handles can be attached.

Turn the handles clockwise (approx. 1 revolution) in the end positions (retracted or extended completely) to secure them properly. Turn the handles anticlockwise (approx. 1 revolution) to unlock them.

Always fully extend and secure the carrying handles before using them to transport the unit. When not in use, always insert and secure the carrying handles to prevent them from restricting your movement when operating the unit. The handles should also be inserted and secured when stored to reduce the risk of accident.

### ***Procedure (fitting the telescopic carrying handles to units without a reel):***

1. Remove protective covers "A" using a screwdriver.



2. Insert telescopic carrying handle "B" in the frame and screw in guide sleeve "C".

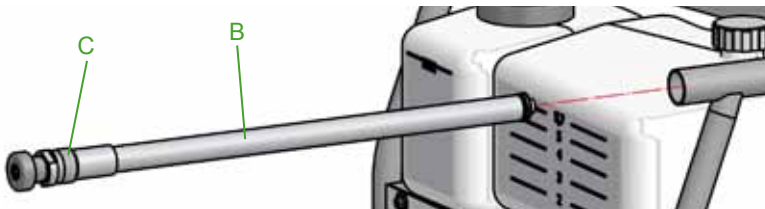

3. Then slide the telescopic carrying handle all the way in and lock in position.

## 8.7 Toolholder

A device must first be detached from retaining clip "D" before it can be removed from the Toolholder.

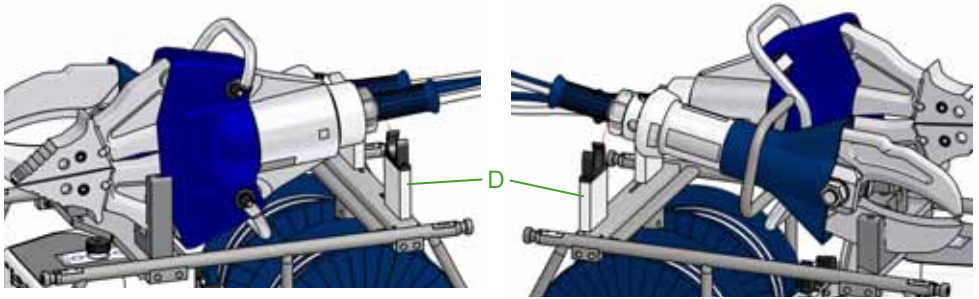

The device is then easy to remove.

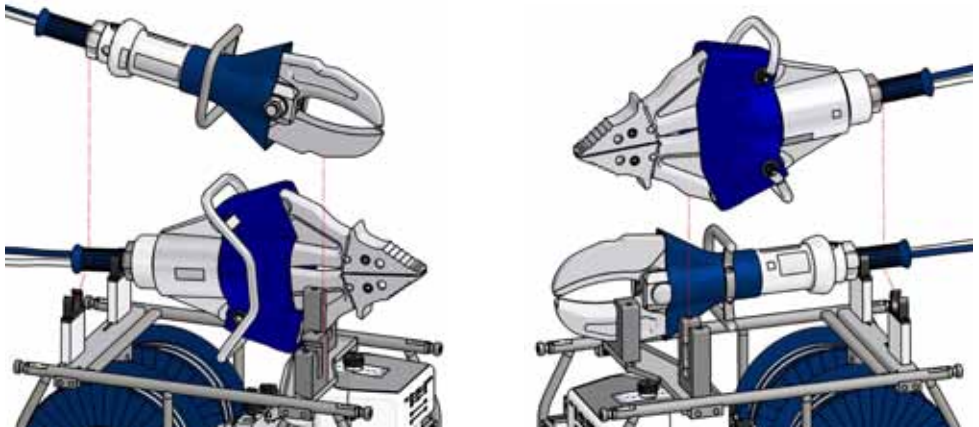

The device is fitted in the reverse order. Make sure that the handle tube on the rescue equipment engages properly in the retaining clip.

**Procedure (fitting and adjusting the Toolholder):**



**NOTE:**

If you wish to install a Toolholder at a later time or adapt an existing mount to a new device, follow the working steps described below.

1. Mount the retaining clip "A" on block "C" and secure using the screws "B".

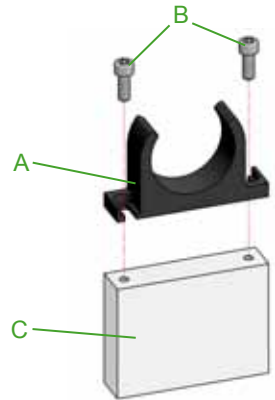

2. Secure the two brackets "D" and "E" to mounting plate "G" using screws "F".

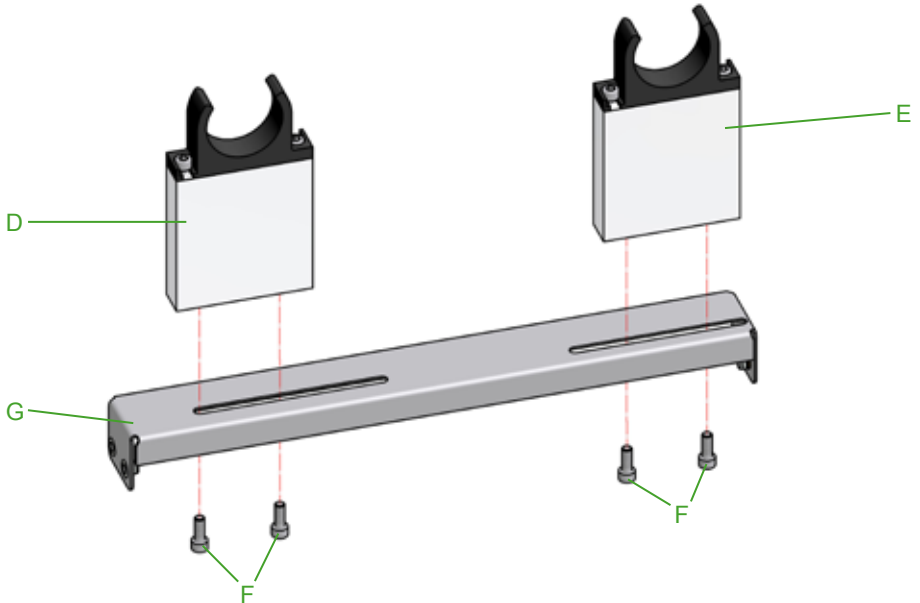

3. Then mount bracket "H" for the spreader and combi tool as well as bracket "J" for the cutters to mounting plate "K" (see illustration below). The brackets are secured in position using screws "L", "M", "N" and "O" as well as washers "P" and nuts "Q". One exception is the retainer for type S700 cutters. Bracket "J" must be installed on mounting block "R" using screws "N" and "O" because of the size of the cutters. Mounting block "R" is then secured to mounting plate "K" using screws "S".

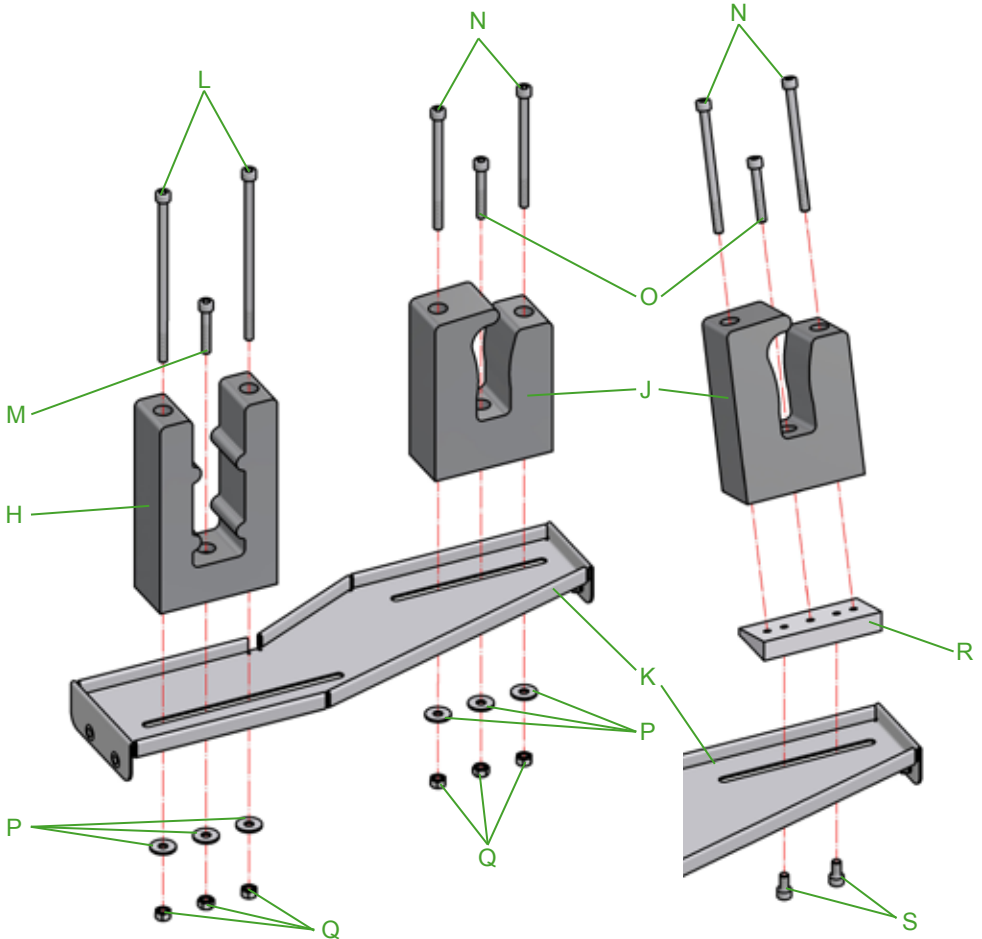

**NOTE:**

For type SP 510 and SP 512 spreaders, the lugs on bracket "H" must be cut off with a knife.

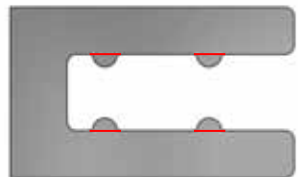

4. Mounting plates "G" and "K" are secured to the frame of the unit using screws "T" as shown in the illustration below.

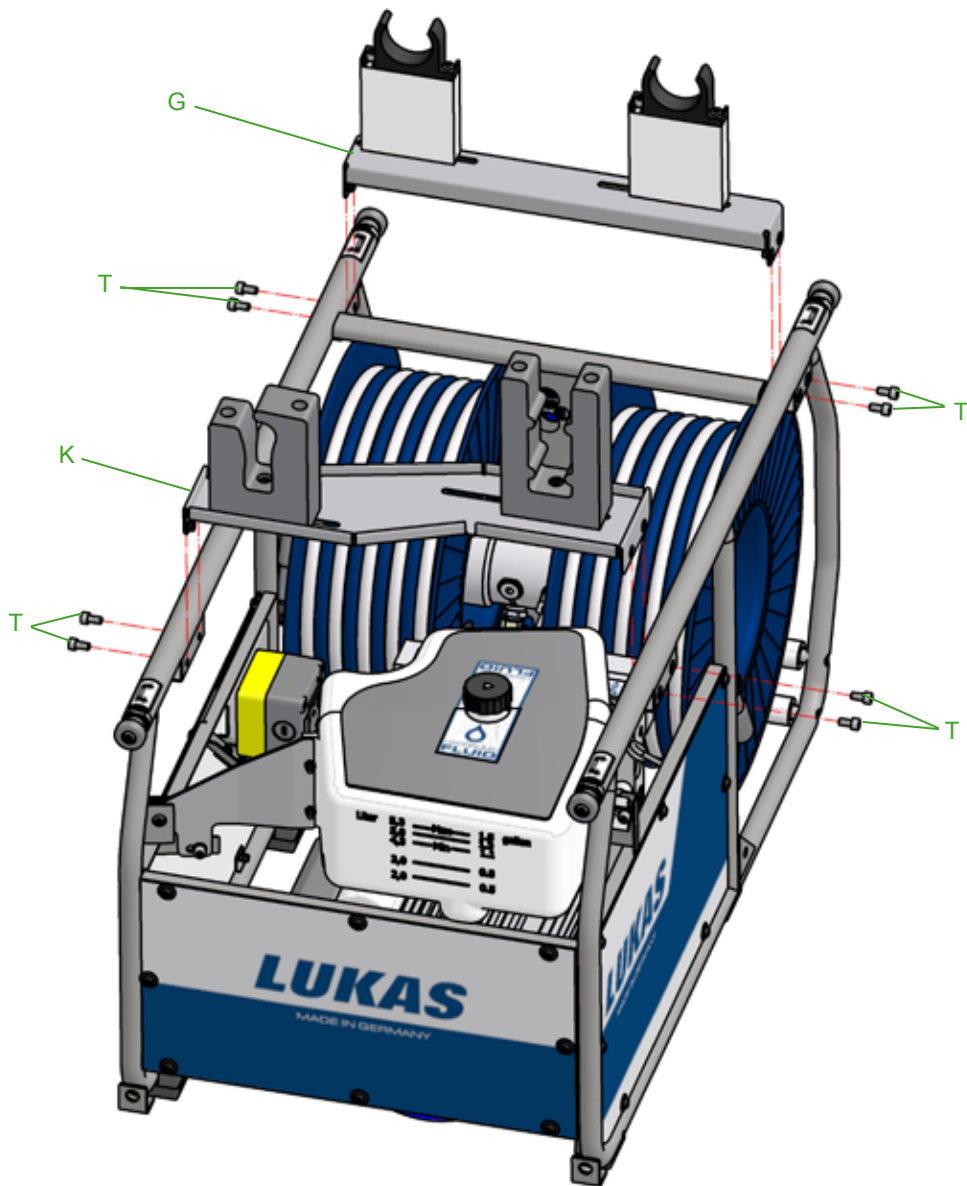

5. Now adapt the brackets to the respective devices. Loosen the fixing screws "F" and "S" or nuts "Q" slightly so that the brackets are easy to move. Do not unscrew the screws or nuts completely.
- The elongated holes "U" in the mounting plates allow you to adapt the brackets to almost every device or individual position of your choice.
- Next tighten all loose fixing screws or nuts to secure the bracket in the selected position.

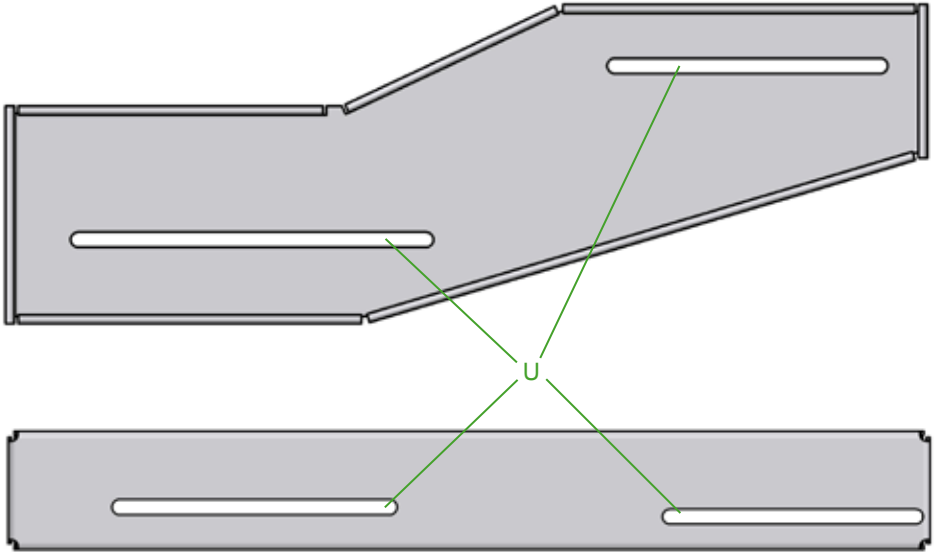

6. The mount is dismantled in reverse order.

## 9. Removing the device / deactivation following operation

Once work has been completed, all connected equipment is to be reset to its base position before the unit is shut down. You can now stop or switch off the motor/engine on the unit and disconnect it from the mains supply, if using an electric motor.



### **ATTENTION when using units with a combustion engine!**

Check that the engine switch is set to "OFF" and remains in that position to prevent anyone from starting the unit unintentionally!



### **NOTE:**

If your unit is equipped with a hose reel, the hoses must be rolled onto the reels correctly!

### Mono-couplings:

If the connected hose lines have to be dismantled during shut-down, decouple the mono-couplings as described in chapter "Connection of the hose lines". Ensure that you replace the dust protection caps onto the mono-coupling halves.

Give the hydraulic unit a general clean before placing in storage. If you intend to store the unit for longer, clean the outside thoroughly and lubricate all mechanical moving parts.



### **CAUTION!**

Depending on the size and the weight of the hydraulic unit, it should be transported to the storage site by one person or several people.

On units with a combustion engine, you should drain the fuel from the tank and disconnect and/or remove the starter battery.

Avoid storing the hydraulic units in a damp environment.

*Please observe the regulations in the separate operating instructions for the hose lines.*

# 10. Tests

The hydraulic units are subject to very high mechanical loads. A visual inspection is therefore to be carried out after every use, however at least one visual inspection is to be carried out every six months.

This reveals wear and tear in good time; punctual replacement of these wearing parts prevents damage to the equipment. Also check regularly that all the securing screws are tightened (if applicable, comply with prescribed tightening torques)

Every 3 years or when there might be doubts regarding the safety or reliability of the unit, an additional functional check is to be carried out (in this connection, comply with the applicable national and international regulations with regard to the maintenance intervals of rescue equipment). In the Federal Republic of Germany, regular safety inspections according to the regulations of the Gesetzliche Unfallversicherung (GUV; 'statutory accident insurance') are mandatory.



### **CAUTION!**

Clean off any dirt before checking the equipment!



### **WARNING / CAUTION / ATTENTION!**

In order to carry out testing, maintenance and repair work, tools appropriate for the job and personal protecting equipment are essential. (use protective shields if required).



LUKAS offers a suitable test kit for the functional check of the hydraulic units.  
*(For specific details, please consult the LUKAS range of accessories or contact your LUKAS dealer).*

## 10.1 Recommended inspection intervals

### 10.1.1 Visual inspection

A visual inspection is to be carried out after every use or every six months.

## 10.1.2 Functional check

<b>Operating period per day</b>	<b>Functional check</b>
up to 1 hour	1 x every year
up to 8 hours	1 x per quarter
up to 24 hours	1 x per month

A functional check should be performed in addition to these intervals if:

- the unit makes suspicious noises,
- there are grounds for suspecting that the unit has sustained internal damage.

Should either of the above occur several times within a month or the maximum pressure is not reached during the functional check, contact LUKAS customer service immediately. See the chapter "Troubleshooting" for contact details.

## 10.2 Hydraulic units with combustion engine

### Visual inspection

#### Hydraulic units

- All hydraulic connections are still tightened
- General tightness, no leakage (sweated oils do not have any influence on the function)
- Obvious damage on the motor/engine, connecting blocks or frame
- Obvious damage to the hydraulic system and/or gasoline tank,
- Side panels present and securely fitted
- Type plate, all activation plates, signs, identification marks and warning labels are present and legible
- All covers (e.g. exhaust deflector) are present and undamaged
- All heat protection mats on the reservoirs are present and undamaged,
- Minimum gap of 10 mm between the reservoirs and hot motor/engine components
- Liquid levels are within the specified tolerances
- Starters are in proper working order and undamaged
- Electric cables are fully functional and undamaged
- Electric starter battery is fully functional and undamaged
- Couplings must be easy to couple
- Dust protection caps must be available
- All necessary accessories (such as sparking plugs, plug spanner and fuel canister) must be present.
- Toolholder (if available) is undamaged and fully functional
- Carrying handles (if available) are undamaged and fully functional

### **Functional check**

- No suspicious noises
- Starter fully functional
- Engine switch fully functional
- Test for maximum load

*(Recommendation: use the LUKAS test kit, including testing instructions, for the functional check).*

## **10.3 Hydraulic units with electric motor**

### **Visual inspection**

#### *Hydraulic units*

- All hydraulic connections are tightened
- General tightness, no leakage (sweated oils do not have any influence on the function)
- Obvious damage to the motor/engine, valve blocks or casing
- Side panels present and securely fitted
- Type plate, all activation plates, signs, identification marks and warning labels are present and legible
- All covers (e.g. fan cover) are present and undamaged
- Liquid levels are within the specified tolerances
- ON/OFF switch in proper working order, undamaged
- Couplings must be easy to couple
- Dust protection caps must be available
- All electrical attachments (such as cables and plugs) must be present and undamaged
- Toolholder (if available) is undamaged and fully functional
- Carrying handles (if available) are undamaged and fully functional

### **Functional check**

- No suspicious noises
- Test for maximum load

*(Recommendation: use the LUKAS test kit, including testing instructions, for the functional check).*

## 10.4 Hose reels

### *Visual inspection*

#### *Hose reel*

- General tightness (no leaks)
- Hose drums rotate easily
- All fixing screws are present and tightened
- Frame and drum undamaged
- Crank handle present, undamaged and fully functional
- Locking brake on double hose reel present and fully functional
- All signs present and legible

#### *Hoses*

- Visual inspection for visible damage and leaks
- Check age of hose (replace after 10 years at the latest)
- Hose connection on mounted reel secure and not leaking
- Couplings must be easy to couple
- Dust caps fitted

### *Functional check*

- Extension hose pairs unroll and roll up smoothly.
- No suspicious noises

## 11. Maintenance and repair

### 11.1 General information

LUKAS type P 650 hydraulic units have an extremely complex design but require minimal maintenance work. **Maintenance work** does not require special training, but knowledge on operating the unit, statutory safety regulations and handling all the necessary tools are basic requirements.



#### **CAUTION!**

Do not exert excess force when performing maintenance work on the unit as this may damage components or compromise the operational safety of the unit

Due to the complex design, **repair work** on the actual hydraulic unit must always be performed by the equipment manufacturer, personnel trained by the equipment manufacturer or authorised LUKAS dealers.



#### **WARNING / CAUTION / ATTENTION!**

During maintenance and repair work, it is essential to wear protective clothing since equipment can still be pressurised even when it is not in operation.

During the work, ensure that all components are particularly clean, since dirt can damage the unit!



### **CAUTION!**

Since LUKAS hydraulic units are designed for top performance, only those components in the spare parts lists of the relevant unit may be replaced.

Further components in the unit may only be replaced if:

- you have taken part in appropriate LUKAS service training,
- you have the express permission of LUKAS Customer Service (after request, verification that permission may be granted. Verification required in each individual case!)

When cleaning units and equipment, note that no cleaning agent may be used that has a pH value outside the range 5 - 8!



### **CAUTION!**

Attention must be paid to ensuring that no operating fluids can escape from units with combustion engines during repair work!

## **11.2 Maintenance work on the hydraulic unit**

### **11.2.1 Cleaning instructions**

The outside of the device must be cleaned from time to time (**not the electrical contacts**) and the metallic surfaces (**not the electrical contacts**) treated with a suitable agent to protect against corrosion.

*(In case of doubt, contact your authorised LUKAS dealer or LUKAS directly!)*

### **11.2.2 Function and load test**

If there is any doubt regarding the safety or reliability of the equipment, a function and load test must also be performed.

LUKAS offers appropriate test equipment.

### **11.2.3 Replacing the hydraulic fluid**

- After approx. 200 deployments, but after three years at the latest, replace the hydraulic fluid
- The fluid should be replaced when it is warmed up.
- The motor must be switched off!
- The old hydraulic fluid must be disposed of properly.

**Procedure:**

1. Place the unit on a slightly raised base so that the drain screw for the hydraulic fluid is easy to access.
2. Place a suitable container under drain screw "A".
3. Open fill cap "B", remove drain screw "A" and seal ring "C", and allow the hydraulic fluid to drain into the container provided.

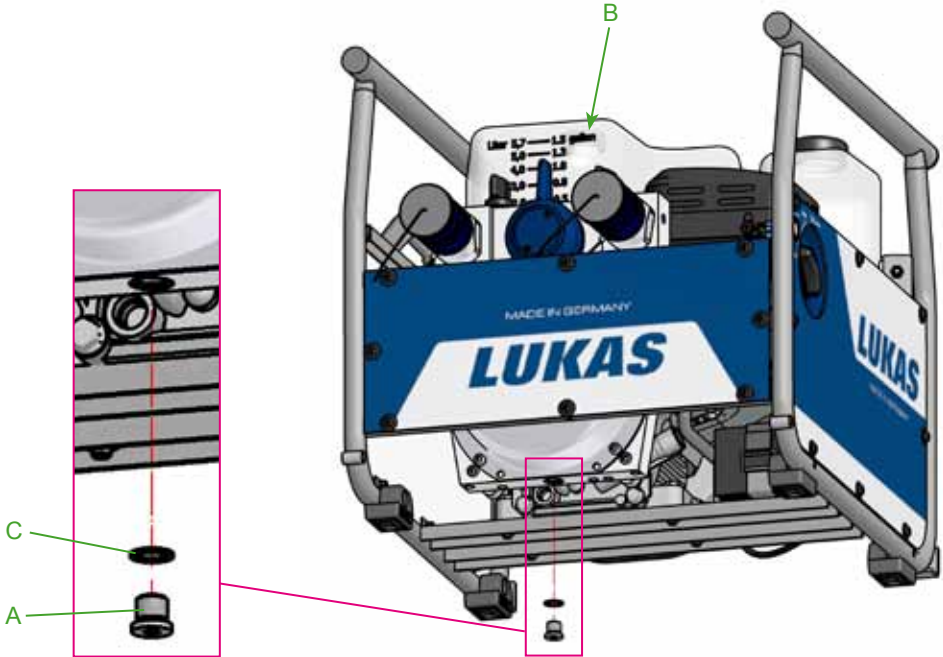

4. Refit components "A" and "C" in the reverse order.
5. Fill fresh hydraulic fluid into the reservoir through the filler neck and then close off the neck with fill cap "B".
6. Finally, the unit must be vented as described in the chapter entitled "Start-up".

### 11.2.4 Replacing signs

All damaged and/or illegible signs (safety notices, type plate etc.) must be replaced.

Procedure:

1. Remove damaged and/or illegible labels.
2. Clean surfaces with industrial alcohol.
3. Affix new signs.

Ensure that you attach the signs in the correct position. If this is no longer known, you should ask your authorised LUKAS dealer or contact LUKAS directly.

## 11.3 Additional maintenance work on units with a combustion engine

*(also read the separate instructions provided by the engine/motor manufacturer)*

*Perform the following maintenance work every **50 operating hours**:*

- Wash the air filter element. Wash more frequently when using the unit in a dirty or dusty environment.
- Check the sparking plug and clean if necessary

*Perform the following maintenance work every **100 operating hours**:*

- Change the engine oil. Change more frequently when operating the unit in a dirty or dusty environment.

*Perform the following maintenance work every **200 operating hours**:*

- Adjust the electrode gap on the sparking plug
- Clean the fuel filter

*Perform the following maintenance work every **500 operating hours**:*

- Replace the sparking plug and filter element
- Clean or adjust the carburettor, valve clearance, valve seat and cylinder head.

*Perform the following maintenance work every **1000 operating hours** or **every 2 years**:*

- Check the starter
- Inspect the engine/motor for damage
- Replace the fuel line.



**NOTE:**

The first oil change must take place after 20 operating hours and the next oil change after 100 hours.

Use a standard articulated sparking plug socket spanner (21 mm) to remove the sparking plug.

A straight / fixed sparking plug socket would damage or break off the sparking plug!

### 11.3.1 Changing and cleaning the air filter

Maintaining the air filter in good condition is essential.

The ingress of dirt due to incorrect installation, incorrect maintenance or unsuitable filter inserts causes damage and excess wear to the engine/motor. Always keep the air filter insert clean.

#### **Procedure:**

1. Remove the rear side panel on the hydraulic unit by detaching the mounting clips.

2. Unhook the cover and remove the filter insert.

3. *Paper insert:*

To clean, tap gently to loosen the dirt and then blow off the dust. Never use oil! Clean the paper insert every 50 operating hours and replace every 200 hours or once a year.

4. *Urethane foam:*

Wash out the insert with fresh water. Squeeze out the water and dry the insert. (DO NOT WRING OUT!!)

5. Then refit the filter.



Air filter

### 11.3.2 Changing, cleaning and adjusting the sparking plug

**Procedure:**

1. Remove the right side panel on the hydraulic unit by detaching the mounting clips.
2. Remove the sparking plug connector. The connector is attached firmly and may require greater effort to remove. During removal, make sure you do not bend the connector or exert lateral force on the sparking plug. In a worst case scenario, you will destroy the sparking plug and will then have to carry out expensive repairs.



Sparking plug connector

Sparking plug

3. Remove the sparking plug from the engine using a 21 mm articulated sparking plug socket for sparking plugs.
4. Remove any soot on the sparking plug using a sparking plug cleaning agent or a brush. If the sparking plug is damaged beyond repair (e.g. electrodes burnt), it must be replaced with a new one.
5. Set the gap between the electrodes to 0.6 - 0.7 mm.

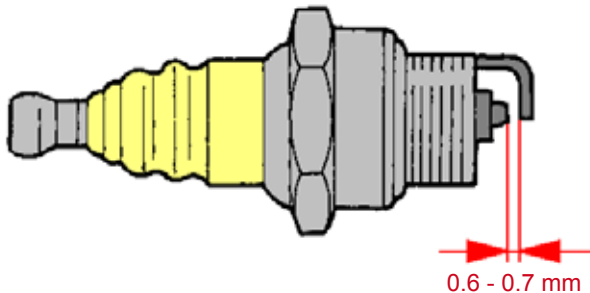

6. Then refit the sparking plug.

### 11.3.3 Changing the engine oil and engine filter

Please refer to the separate operating instructions provided by the engine manufacturer for information on changing the engine oil and the engine filter.

### 11.3.4 Externally charging and replacing the starter battery

**Procedure:**

1. Remove the left side panel "A" on the hydraulic unit by detaching the mounting clips "B".
2. Starter battery "C" is now visible. First disconnect the negative ("-") and then the positive terminal ("+") on the battery.

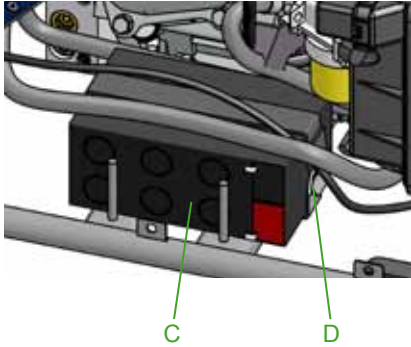
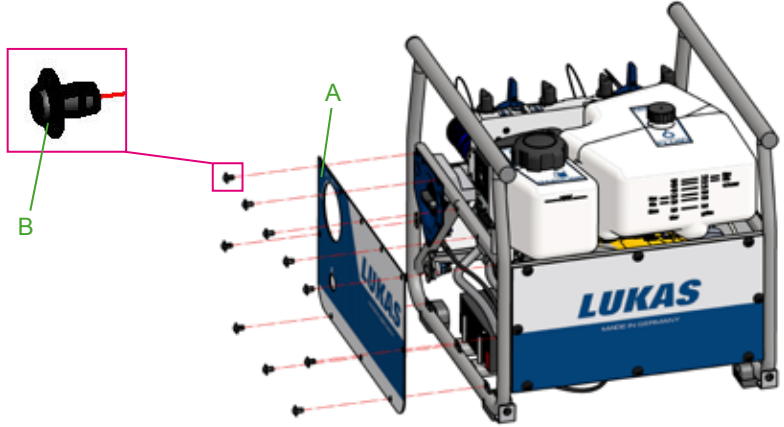

3. If you would like to charge the starter battery using an external charger, connect the device now. (Read the instruction manual accompanying the charger)

If the battery is defective, it must be replaced. Loosen attachment belt "D" and remove the battery. When replacing the battery, make sure that you insert the new battery as shown in the illustration.

The unit is assembled in reverse order.

## 11.4 Maintenance work on mounted hose reel

A visual inspection of the fitted hoses and couplings is to be carried out after every use or every six months. Components showing obvious signs of damage or leaks must be replaced. If screwed connections start to leak, check whether they are tight first of all. If the leak continues after the screwed connection has been tightened, the screwed connection is defective and must be replaced.

Hose lines will age over time and must be replaced according to statutory regulations.

If there are no applicable statutory regulations, the hoses must be replaced after 10 years at the latest. *(Read the separate operating instructions for the hoses.)*

### 11.4.1 Replacing the extension hose lines

#### **Procedure:**

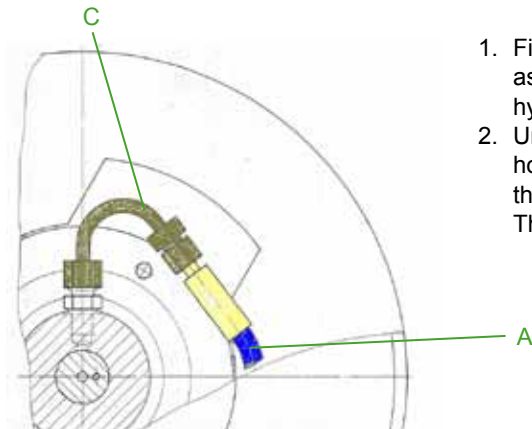

1. First of all, empty the hydraulic reservoir as described in the chapter "Replacing the hydraulic fluid".
2. Unroll extension hoses "A". Slide protective hoses "B" over elbow piece "C", leaving the screwed connection uncovered. Then unscrew the hoses.



3. Screw the new extension hoses onto the elbow pieces with a torque of  $M_A = 40 \text{ Nm}$ . Do not forget to slide protective hoses "B" back over the screwed connections.

**The protective hose set must be fitted to the reel!**



B

4. Roll up the extension hose again.
5. The hydraulic fluid reservoir must then be filled and the unit vented.

#### 11.4.2 Mono-couplings

The mono-couplings must be replaced if:

- there is external damage,
- the lock does not function correctly,
- hydraulic fluid continues to leak in a coupled/uncoupled state.



#### **WARNING / CAUTION / ATTENTION!**

Never repair couplings: they must be replaced with genuine LUKAS parts!

#### *Procedure for couplings on the valve block:*

1. First of all, empty the hydraulic reservoir as described in the chapter "Replacing the hydraulic fluid".
2. Remove the screwed connections on the coupling.
3. Remove the couplings and seals underneath
4. Place the new coupling on the valve block together with the seals.
5. Secure the couplings again using the screws and tighten these to a torque of  $M_A = 40 \text{ Nm}$ .
6. The hydraulic fluid reservoir must then be filled and the unit vented.

Procedure for couplings on hose pairs:

1. First of all, empty the hydraulic reservoir as described in the chapter "Replacing the hydraulic fluid".
2. Pull the cover back from the couplings.

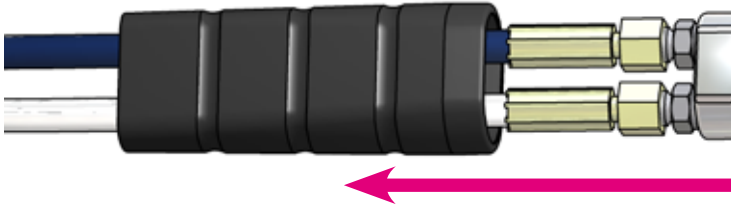

3. Loosen the union nuts on the hose lines and remove the coupling.

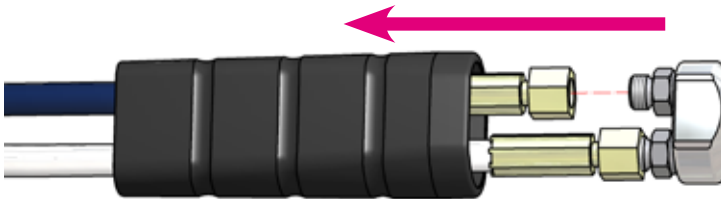

**CAUTION!**

As the case may be, make sure that port 'T' / 'T1' of the hose reel is always connected to port 'T' of the mono-coupling.

4. Position the new coupling and tighten the union nuts on the hose lines to a torque of  $M_A = 40 \text{ Nm}$  and push the cover back over the couplings.



5. The hydraulic fluid reservoir must then be filled and the unit vented.

## 12. Troubleshooting

In the case of defects which directly affect the motor / engine, please consult the separate operating instructions of the motor / engine manufacturer.

Trouble	Check	Cause	Solution
Electric motor does not operate when the switch is actuated or does not operate at full power	Check the connection cable on the electric motor	Power cable not connected	Connect power cable correctly
		Defect on connection cable	Shut down immediately and have repaired by authorised dealer, motor / engine manufacturer or directly by LUKAS
	Extension cable or cable drum used?	Cable not completely uncoiled	Uncoil the power cable completely
		Cable losses in extension cable or cable drums too great (electrical resistance)	Use a different suitable extension cable or cable drum.
	Electric motor connected to a suitable accumulator?	Battery flat	Charge battery
		Electric motor not suitable for accumulator operation	Connect the motor to a different suitable power supply
	Electric safety device in power supply has triggered	Power supply not suitable for electric motor	Connect the motor to a different suitable power supply
		Electric safety device in power supply has triggered although it is suitable for operation of the motor.	Safety device too low, use a different fuse.
	Are all valves depressurised (base position)?	Electric motor defective or overloaded due to another defect in the unit	Shut down immediately and have repaired by authorised dealer, motor / engine manufacturer or directly by LUKAS

<b>Trouble</b>	<b>Check</b>	<b>Cause</b>	<b>Solution</b>
Combustion engine will not start	Check fuel level in tank	Fuel tank empty	Top up fuel
	Electric starter present?	Electric starter battery flat	Charge electric starter battery or use pull cord starter
	Check fuel line	Fault in the fuel line	Shut down immediately and have repaired by authorised dealer, motor / engine manufacturer or directly by LUKAS
	Check the starter button and engine switch	Starter button or pull cord starter not actuated	Actuate starter button or pull cord starter
		Engine switch not set to "Choke"	Set engine switch to "Choke"
	Hydraulic unit or motor / engine not suitable for the working environment	Ambient temperature too low	For the solution, consult the separate operating instructions of the engine / motor manufacturer.
			Use a different hydraulic or operating fluid that is suitable for the corresponding ambient temperatures (see chapter "Technical data")
			Use a different more suitable hydraulic unit.
	Check air filter	Air filter contaminated	Have the engine set to the altitude of application by an authorised dealer, motor / engine manufacturer or LUKAS directly (only if the unit is to be used frequently at this altitude).
			Clean or replace the air filter.
Are all valves depressurised (base position)?	Combustion engine defective or overloaded due to another defect in the unit	Have repaired by authorised dealer, motor / engine manufacturer or directly by LUKAS	

<b>Trouble</b>	<b>Check</b>	<b>Cause</b>	<b>Solution</b>
The motor / engine is running, but the connected rescue equipment does not move when the valve is actuated.	Check hose line	Hose line not connected properly or is damaged	Inspect the connection of the hose line and, if necessary, reconnect
	Check the position of the valve lever on the pump block of the hydraulic unit	Valve not switched to pressurise the supply line.	Switch valve to pressurise the supply line.
		Defective pump unit	Have repaired by authorised dealer or directly by LUKAS
	Connect another device and check whether it functions when the valve is actuated	The previously connected device is defective.	For the solution, consult the operating instructions for the connected device
		Mono-coupling (female) defective	Replace mono-coupling (female)
The connected rescue equipment does not move on activation of the valve, or moves only very slowly or unevenly.	Connect another device and check whether it functions when the valve is actuated	The previously connected device is defective.	For the solution, consult the operating instructions for the connected device
		Check the position of the valve lever on the pump block of the hydraulic unit	Pressure relief on the unit is still active (circulation at static pressure)
		Defective pump unit	Have repaired by authorised dealer or directly by LUKAS
		Air in hydraulic system	Vent the hydraulic system
		Mono-coupling (female) defective	Replace mono-coupling (female)

<b>Trouble</b>	<b>Check</b>	<b>Cause</b>	<b>Solution</b>
Connected rescue device does not reach its final position	Check hydraulic fluid volume in hydraulic reservoir	Insufficient fluid in the hydraulic reservoir	Top up hydraulic fluid to the maximum filling level <b>Caution! Before topping up the rescue equipment, return to the base position!</b>
		Usable hydraulic fluid volume of the unit is insufficient	Use a different rescue device with a required quantity below the maximum usable quantity of the unit
Connected rescue device does not reach its specific performance data		Maximum permitted operating pressure of the pump is not reached	Have the pressure limiting valve reset or repaired by authorised dealer or directly by LUKAS
		Defective pump block	Have repaired by authorised dealer or directly by LUKAS
		Connected device is defective	For the solution, consult the operating instructions for the connected device
During the functional check: A pressure gauge installed between the rescue equipment and the hydraulic power pack does not indicate the maximum operating pressure of the equipment.	Check the details of the rescue device	The operating pressure of the connected rescue device is locked internally	No repair or fault rectification required
		Connected rescue device is defective	Consult the separate operating manual for the connected rescue device
		Hydraulic unit defective	Have repaired by authorised dealer or directly by LUKAS

<b>Trouble</b>	<b>Check</b>	<b>Cause</b>	<b>Solution</b>
Fluid escaping from the hydraulic fluid reservoir	Connected device is not yet in base position and fluid is escaping from the filler screw?	Return of the hydraulic fluid from the rescue device exceeds the reservoir's maximum quantity when filled.	Reduce the fill level in the hydraulic fluid reservoir to the "minimum" mark, move the device to base position and then fill the fluid back up to "maximum"
	Fluid leaking from a different place?	Leak on reservoir, lines or seals	Replace defective components or have repaired by authorised dealer or directly by LUKAS
Leaking fluid between engine and flange bearing		Radial shaft seal on the drive shaft is defective	Have repaired by authorised dealer or directly by LUKAS
Hydraulic fluid milky and cloudy		Water / condensation in the system	Immediately replace hydraulic fluid
Hose line cannot be coupled		Pressure too high (e.g. caused by excessive ambient temperature)	Switch valve block to circulation at static pressure
		Coupling defective	Coupling must be replaced immediately
Impossible to retract or extend carrying handles.		Carrying handles are still locked	Unlock carrying handles and extend.
		Carrying handles or frame defective	Replace the carrying handles or frame.
Impossible to lock or unlock carrying handles		Carrying handles or frame defective	Replace the carrying handles or frame.
Hose reel does not turn		Locking brake still applied	Release locking brake
		Hose reel defective	Have repaired by authorised dealer or directly by LUKAS
Impossible to attach equipment to the Toolholder		Toolholder set incorrectly	Adjust the Toolholder to accommodate the device.
		Toolholder defective	Replace Toolholder.

<b>Trouble</b>	<b>Check</b>	<b>Cause</b>	<b>Solution</b>
It is frequently not possible to couple hose lines		Hydraulic fluid not adapted to the application situation	Hydraulic fluid must be replaced (see chapter "Recommended hydraulic fluids")
		Coupling defective	Coupling must be replaced immediately
Leak in the couplings		Coupling defective	Coupling must be replaced immediately
Fluid escaping from hoses or joints		Leak, possible damage	Replace hoses
Surface of the hoses damaged		Mechanical damage or contact with aggressive agents	Replace hoses
Hydraulic fluid escaping from inside the hose drum.	Extension hose pairs damaged?	Hose lines defective.	Replace hoses
	Screwed connection on the hose lines tight?	Connection between hose lines and elbow pieces not tight enough.	Tighten the screwed connections between the hose lines and elbow pieces.
	Screwed connection between elbow piece and shaft leaking?	Defective elbow piece or seal	Replace the elbow piece or seal
		Defective shaft	Repair of fault by authorised dealer, specially trained LUKAS staff or directly by LUKAS
Hydraulic fluid escaping from the connections between the connection hoses and reel shaft	Connection hoses damaged?	Hose lines defective.	Replace hoses
	Screwed connection on the hose lines tight?	Hose lines or male couplings not tight enough.	Tighten the screwed connections on the hose lines or male couplings.
	Leak between male coupling and shaft?	Male coupling not tight enough	Tighten screwed connection.
		Seal between male coupling and shaft defective?	Replace seal.
		Male coupling defective	Replace male coupling
Connection between hub and shaft leaking		Seal between hub and shaft defective.	Repair of fault by authorised dealer, specially trained LUKAS staff or directly by LUKAS

If it is not possible to rectify the malfunctions, inform an authorised LUKAS dealer or the LUKAS Customer Service department immediately!

The address of the LUKAS Customer Service Department is:

**LUKAS** Hydraulik GmbH

*A unit of the IDEX Corporation*

Weinstrasse 39, D-91058 Erlangen

Phone: (+49) 09131 / 698 - 348

Fax.: (+49) 09131 / 698 - 353

## 13. Technical data

Because all values are subject to tolerances, there may be small differences between the data for your device and the data in the following tables!

The values may also differ because of reading inaccuracies and/or tolerances in the measuring equipment used.



### NOTE:

The following tables contain only the technical data required for standard acceptance.

Additional data concerning your unit can be obtained from LUKAS on request.

The restriction for the maximum fill quantity of the hydraulic reservoir is calculated from the "operability in inclined position" specifications in the relevant standards.

### 13.1 Unit

#### 13.1.1 Basic unit dimensions

*Units without hose reel:*

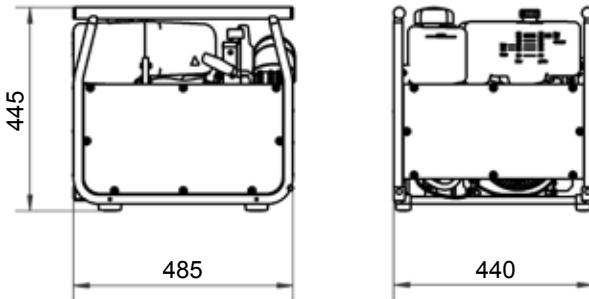

*Units with hose reel:*

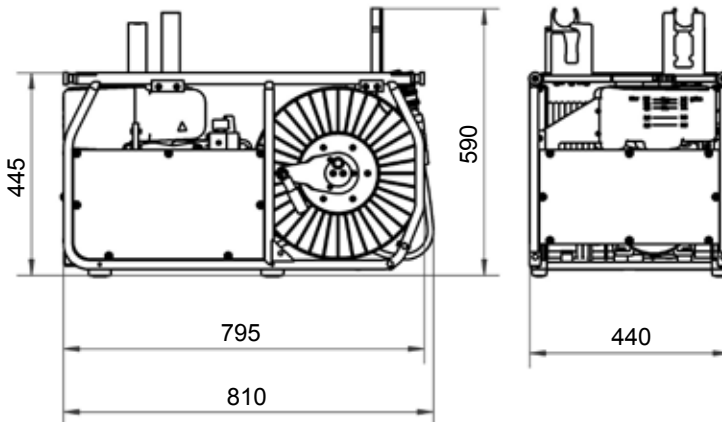

### 13.1.2 Type series P 650 SE and P 650 SE - DHR

Device type		P 650 SE	P 650 SE - DHR
Ref. number		175760000	175762000
Motor type		230V / 50 Hz ; Electric motor	
Power	[kW]	2,2	
	[HP]	2.95	
Speed	[min <sup>-1</sup> ]	2960	
	[rpm.]		
Max. operating pressure (HP) <sup>1)</sup>	[MPa] <sup>3)</sup>	70	
	[psi.]	10,153	
Max. operating pressure (LP) <sup>2)</sup>	[MPa] <sup>3)</sup>	14	
	[psi.]	2,031	
Flow rate (HP) <sup>1)</sup>	[l/min]	2 x 0,7	
	[gal.-US/min]	2 x 0.18	
Flow rate (LP) <sup>2)</sup>	[l/min]	2 x 2,55	
	[gal.-US/min]	2 x 0.67	
Max. fill quantity Hydraulic fluid	[l]	5,5	
	[gal.-US]	1.45	
Max. usable quantity Hydraulic fluid	[l]	4,8	
	[gal.-US]	1.27	
Weight (incl. 4,3l hydraulic fluid)	[kg]	41,0	80,0
	[lbs.]	90.4	176.4
Starting current	[A]	32	
Valve typ		Simultaneous operation	
Hose reel		NO	YES
Max. number of device connections		2	
Additional series equipment		-	Carrying handles Toolholder

<sup>1)</sup> HP = High pressure

<sup>2)</sup> LP = Low pressure

<sup>3)</sup> 1MPa = 10 bar

### 13.1.3 Type series P 650 SG

<b>Gerätetyp</b>		P 650 SG	P 650 SG - ES
<b>Artikelnummer</b>		175710000	175720000
<b>Motor type</b>		4-stroke gasoline engine	
<b>Power</b>	[kW] <i>[HP]</i>	4,2 <i>5.63</i>	
<b>Speed</b>	[min <sup>-1</sup> ] <i>[rpm.]</i>	3300	
<b>Max. operating pressure (HP)<sup>1)</sup></b>	[MPa] <sup>3)</sup> <i>[psi.]</i>	70 <i>10,153</i>	
<b>Max. operating pressure (LP)<sup>2)</sup></b>	[MPa] <sup>3)</sup> <i>[psi.]</i>	14 <i>2,031</i>	
<b>Flow rate (HP)<sup>1)</sup></b>	[l/min] <i>[gal.-US/min]</i>	2 x 0,9 <i>2 x 0.24</i>	
<b>Flow rate (LP)<sup>2)</sup></b>	[l/min] <i>[gal.-US/min]</i>	2 x 3,1 <i>2 x 0.82</i>	
<b>Max. fill quantity Hydraulic fluid</b>	[l] <i>[gal.-US]</i>	5,5 <i>1.45</i>	
<b>Max. usable quantity Hydraulic fluid</b>	[l] <i>[gal.-US]</i>	4,8 <i>1.27</i>	
<b>Max. fill quantity gasoline</b>	[l] <i>[gal.-US]</i>	1,65 <i>0.44</i>	
<b>Weight (incl. gasoline and 4,3l hydraulic fluid)</b>	[kg] <i>[lbs.]</i>	36,5 <i>80.5</i>	42,0 <i>92.6</i>
<b>Valve type</b>		Simultaneous operation	
<b>Max. number of device connections</b>		2	
<b>Additional series equipment</b>			Electric starter

<sup>1)</sup> HP = High pressure

<sup>2)</sup> LP = Low pressure

<sup>3)</sup> 1MPa = 10 bar

### 13.1.4 Type series P 650 SG - DHR

Gerätetyp		P 650 SG - DHR	P 650 SG - ES - DHR
Artikelnummer		175712000	175722000
Motor type		4-stroke gasoline engine	
Power	[kW] [HP]	4,2 5.63	
Speed	[min <sup>-1</sup> ] [rpm.]	3300	
Max. operating pressure (HP) <sup>1)</sup>	[MPa] <sup>3)</sup> [psi.]	70 10,153	
Max. operating pressure (LP) <sup>2)</sup>	[MPa] <sup>3)</sup> [psi.]	14 2,031	
Flow rate (HP) <sup>1)</sup>	[l/min] [gal.-US/min]	2 x 0,9 2 x 0.24	
Flow rate (LP) <sup>2)</sup>	[l/min] [gal.-US/min]	2 x 3,1 2 x 0.82	
Max. fill quantity Hydraulic fluid	[l] [gal.-US]	5,5 1.45	
Max. usable quantity Hydraulic fluid	[l] [gal.-US]	4,8 1.27	
Max. fill quantity gasoline	[l] [gal.-US]	1,65 0.44	
Weight (incl. gasoline and 4,3l hydraulic fluid)	[kg] [lbs.]	76 167.6	81,5 179.7
Valve typ		Simultaneous operation	
Max. number of device connections		2	
Additional series equipment		Carrying handles Toolholder	Carrying handles Toolholder Electric starter

<sup>1)</sup> HP = High pressure

<sup>2)</sup> LP = Low pressure

<sup>3)</sup> 1MPa = 10 bar

### 13.1.5 Type series P 650 4G

<b>Device type</b>		P 650 4G	P 650 4G - ES
<b>Ref. number</b>		175730000	175740000
<b>Motor type</b>		4-stroke gasoline engine	
<b>Power</b>	[kW]	5,1	
	<i>[HP]</i>	<i>6.84</i>	
<b>Speed</b>	[min <sup>-1</sup> ]	3600	
	<i>[rpm.]</i>		
<b>Max. operating pressure (HP)<sup>1)</sup></b>	[MPa <sup>3)</sup> ]	70	
	<i>[psi.]</i>	<i>10,153</i>	
<b>Max. operating pressure (LP)<sup>2)</sup></b>	[MPa <sup>3)</sup> ]	14	
	<i>[psi.]</i>	<i>2,031</i>	
<b>Flow rate (HP)<sup>1)</sup></b>	[l/min]	4 x 0,7	
	<i>[gal.-US/min]</i>	<i>4 x 0.18</i>	
<b>Flow rate (LP)<sup>2)</sup></b>	[l/min]	4 x 2,55	
	<i>[gal.-US/min]</i>	<i>4 x 0.67</i>	
<b>Max. fill quantity Hydraulic fluid</b>	[l]	5,5	
	<i>[gal.-US]</i>	<i>1.45</i>	
<b>Max. usable quantity Hydraulic fluid</b>	[l]	4,8	
	<i>[gal.-US]</i>	<i>1.27</i>	
<b>Max. fill quantity gasoline</b>	[l]	1,65	
	<i>[gal.-US]</i>	<i>0.44</i>	
<b>Weight (incl. gasoline and 5,5l hydraulic fluid)</b>	[kg]	43,5	49,0
	<i>[lbs.]</i>	<i>95.9</i>	<i>108.0</i>
<b>Valve typ</b>		4POWER	
<b>Max. number of device connections</b>		4	
<b>Additional series equipment</b>			Electric starter

<sup>1)</sup> HP = High pressure

<sup>2)</sup> LP = Low pressure

<sup>3)</sup> 1MPa = 10 bar

### 13.1.6 Type series P 650 4G - DHR

Device type		P 650 4G - DHR	P 650 4G - ES - DHR
Ref. number		175732000	175742000
Motor type		4-stroke gasoline engine	
Power	[kW]	5,1	
	[HP]	6.84	
Speed	[min <sup>-1</sup> ]	3600	
	[rpm.]		
Max. operating pressure (HP) <sup>1)</sup>	[MPa] <sup>3)</sup>	70	
	[psi.]	10,153	
Max. operating pressure (LP) <sup>2)</sup>	[MPa] <sup>3)</sup>	14	
	[psi.]	2,031	
Flow rate (HP) <sup>1)</sup>	[l/min]	4 x 0,7	
	[gal.-US/min]	4 x 0.18	
Flow rate (LP) <sup>2)</sup>	[l/min]	4 x 2,55	
	[gal.-US/min]	4 x 0.67	
Max. fill quantity Hydraulic fluid	[l]	5,5	
	[gal.-US]	1.45	
Max. usable quantity Hydraulic fluid	[l]	4,8	
	[gal.-US]	1.27	
Max. fill quantity gasoline	[l]	1,65	
	[gal.-US]	0.44	
Weight (incl. gasoline and 5,5l hydraulic fluid)	[kg]	86	91,5
	[lbs.]	189.6	201.8
Valve typ		4POWER	
Max. number of device connections		4	
Additional series equipment		Carrying handles Toolholder	Carrying handles Toolholder Electric starter

<sup>1)</sup> HP = High pressure

<sup>2)</sup> LP = Low pressure

<sup>3)</sup> 1MPa = 10 bar

### 13.2 Noise emissions

Device type	P 650 S E and P 650 S E - DHR	P 650 S G and P 650 S G - DHR	P 650 4 G and P 650 4 G - DHR
<b>No-load operation</b> (measuring distance 1 m) [dB(A)]	73	82	83
<b>Full-load operation</b> (measuring distance 1 m) [dB(A)]	80	87	87
<b>No-load operation</b> (measuring distance 4 m) [dB(A)]	67	76	76
<b>Full-load operation</b> (measuring distance 4 m) [dB(A)]	75	81	81

### 13.3 Sparking plug

**Sparking plug type:** BR6HS (NGK)

### 13.4 Sparking plug socket

**Articulated sparking plug socket, size 21 mm**

### 13.5 Fuel

**Fuel:** Lead-free gasoline  
ROZ 91 to ROZ 98  
Max. permissible bioethanol  
content: 10%

### 13.6 Engine oil

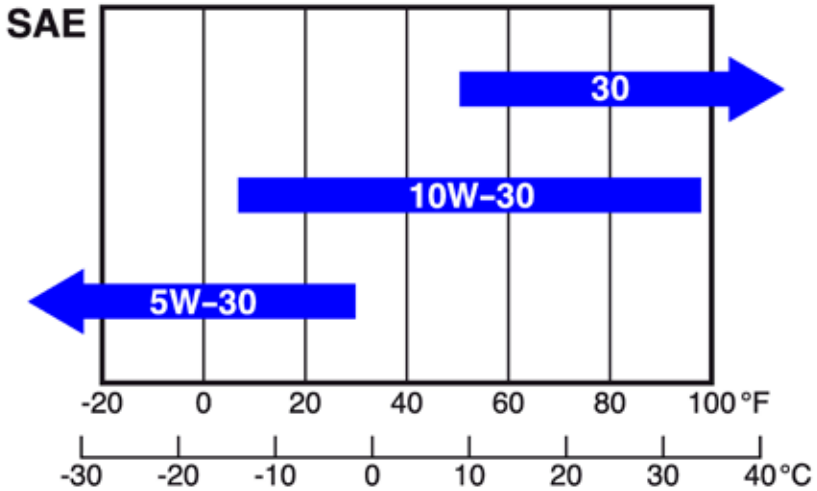

### 13.7 Hydraulic fluid recommendation

Mineral oil DIN ISO 6743-4 for LUKAS hydraulic equipment and others

	Oil temperature range	Oil code	Viscosity rating	Remarks
A	-20 .... +55°C	HM 10	VG 10	

	Oil temperature range	Oil code	Viscosity rating	Remarks
A	-4.0 .... +131°F	HM 10	VG 10	

recommended viscosity range: 10...200 mm<sup>2</sup>/s (10...200 cSt)

Supplied with HM 10 DIN ISO 6743-4.



**CAUTION!**

You must always contact your local authorised LUKAS dealer or LUKAS directly before using hydraulic fluid from other manufacturers.

### 13.8 Operating and storage temperature range

<b>Operating temperature</b>	[°C] / [°F]	-20 ... +55	-4 ... +131
<b>Ambient temperature</b> (device in operation)	[°C] / [°F]	-25 ... +45	-13 ... +113
<b>Storage temperature</b> (device not in operation)	[°C] / [°F]	-30 ... +60	-22 ... +140

# 14. EC Declaration of Conformity

## LUKAS

LUKAS Hydraulik GmbH  
Weinstraße 30,  
D-91055 Erlangen / Germany  
www.lukas.com

## IDEX RESCUE

Dinglee  
Hurst  
LUKAS  
Vetter

### EG-Konformitätserklärung / EC Declaration of Conformity

Im Sinne der EG-Maschinenrichtlinie 2006/42/EG, Anhang II A  
*In accordance with the EC Machinery Directive 2006/42/EG, Appendix II A*

Hiermit erklären wir, dass die nachfolgend bezeichneten hydraulischen Motorzumpen:  
*We hereby declare that the following hydraulic power units*

Artikelnr. / Item No.	Modell / Type
175710000; 175720000	P 650 SG; P650 SG-ES
175730000; 175740000	P 650 4G; P650 4G-ES
175760000	P 650 SE

- in der von uns gelieferten Ausführung den Bestimmungen der Maschinenrichtlinie 2006/42/EG (ersetzte Richtlinie 98/37/EG) und den sie umsetzenden nationalen Rechtsvorschriften entspricht.  
Berücksichtigt wurden insbesondere die Normen:
  - DIN EN ISO 12100:2010, Ausgabe: 2011-03 - Sicherheit von Maschinen – Allgemeine Gestaltungsgrundsätze – Risikobeurteilung und Risikominderung
  - DIN EN 13204, Ausgabe: 2005-05 – Doppelt wirkende hydraulischen Rettungsgeräte für die Feuerwehr und Rettungsdienste – Sicherheits- und Leistungsanforderungen
- *in the versions supplied by us conform to the EC Machinery Directive 2006/42/EG (replaced directive 98/37/EG) and the national statutory provisions that implement them.*  
*The following standards have been taken into particular consideration:*
  - *DIN EN ISO 12100:2010, publication date: 2011-03 – Safety of machinery - General principles for design - Risk assessment and risk reduction*
  - *DIN EN 13204, publication date: 2005-05 – Double acting hydraulic rescue tools for fire and rescue service use – Safety and performance requirements*

Bei einer nicht mit uns abgestimmten Änderung oder Verwendung der Maschine/Ausrüstung verliert diese Erklärung ihre Gültigkeit.  
*This declaration loses validity in the case of alterations or usage of the machinery/equipment not approved by LUKAS.*

Erlangen, 28.09.2011



Wolfgang Bertel,  
Leiter Konstruktion / Manager Design  
LUKAS Hydraulik GmbH



Thomas Littwin  
Konstrukteur / Designer  
LUKAS Hydraulik GmbH

An IDEX Fire & Safety Business

LUKAS Hydraulik GmbH • Sitz/Domicile: Erlangen • Registergericht/Registration: Fürth HRB 6095  
Geschäftsführer/Managing Directors: Sven G. Kilmner, MBA; Rainer Siegmund, Dipl.-Betriebsw. (FH)  
Tel.: +49(0)9131898-0 • Fax: +49 (0)9131898-394 • E-Mail: [lukas.info@texcorp.com](mailto:lukas.info@texcorp.com)

Bank:  
J.P. Morgan AG Frankfurt a.M.

BLZ/Bank Code:  
501 101 00

Kto. Nr./Account No.:  
6 161 507 041

S.W.I.F.T.-Code:  
CHASDEFX

IBAN:  
DE24 5011 0000 0161 5070 41

## EG-Konformitätserklärung / EC Declaration of Conformity

Im Sinne der EG-Maschinenrichtlinie 2006/42/EG, Anhang II A  
In accordance with the EC Machinery Directive 2006/42/EG, Appendix II A

Hiermit erklären wir, dass die nachfolgend bezeichneten hydraulischen Motorpumpen  
We hereby declare that the following hydraulic power units

Artikelnr. / Item No.	Modell / Type
175712000; 175722000	P 650 SG-DHR; P650 SG-ES-DHR
175732000; 175742000	P 650 4G-DHR; P650 4G-ES-DHR
175762000	P 650 SE-DHR

- in der von uns gelieferten Ausführung den Bestimmungen der Maschinenrichtlinie 2006/42/EG (ersetzt Richtlinie 98/37/EG) und den sie umsetzenden nationalen Rechtsvorschriften entspricht.  
Berücksichtigt wurden insbesondere die Normen:
  - DIN EN ISO 12100:2010, Ausgabe: 2011-03 - Sicherheit von Maschinen – Allgemeine Gestaltungsgrundsätze – Risikobeurteilung und Risikominderung
  - DIN EN 13204, Ausgabe: 2005-05 – Doppelt wirkende hydraulischen Rettungsgeräte für die Feuerwehr und Rettungsdienste – Sicherheits- und Leistungsanforderungen
- in the versions supplied by us conform to the EC Machinery Directive 2006/42/EG (replaced directive 98/37/EG) and the national statutory provisions that implement them.  
The following standards have been taken into particular consideration:
  - DIN EN ISO 12100:2010, publication date: 2011-03 – Safety of machinery - General principles for design - Risk assessment and risk reduction
  - DIN EN 13204, publication date: 2005-05 – Double acting hydraulic rescue tools for fire and rescue service use – Safety and performance requirements

Bei einer nicht mit uns abgestimmten Änderung oder Verwendung der Maschine/Ausrüstung verliert diese Erklärung ihre Gültigkeit.

This declaration loses validity in the case of alterations or usage of the machinery/equipment not approved by LUKAS.

Erlangen, 28.09.2011



Wolfgang Berleff  
Leiter Konstruktion / Manager Design  
LUKAS Hydraulik GmbH



Thomas Littwin  
Konstrukteur / Designer  
LUKAS Hydraulik GmbH

An IDEX Fire & Safety Business

LUKAS Hydraulik GmbH • Sta/Domicile: Erlangen • Registergericht/Registration: Fürth HRB 6505  
Geschäftsführer/Managing Directors: Sven G. Kähler, MBA; Rainer Sieglmund, Dipl.-Betriebsw. (FH)  
Tel.: +49 (0)9131/698-0 • Fax: +49 (0)9131/698-394 • E-Mail: [lukas.info@idexcorp.com](mailto:lukas.info@idexcorp.com)

Bank:  
J.P. Morgan AG Frankfurt a.M.

BLZ/Bank Code  
501 106 00

Kto.-Nr./Account No.  
0 101 507 041

S.W.I.F.T.-Code  
CHASDEFX

IBAN  
DE44 5011 0800 0161 5070 41

## 15. Notes



## **WARNING / CAUTION / ATTENTION!**



Before connecting equipment, make sure that **all the components used** are suitable for the **maximum operating pressure of the hydraulic unit!** In cases of doubt, you **must consult** LUKAS directly before connecting the equipment!



Please dispose of all packaging materials and dismantled parts properly.

---

## **LUKAS** Hydraulik GmbH

*A unit of the IDEX Corporation*

Weinstrasse 39, D-91058 Erlangen

Phone: (+49) 0 91 31 / 698 - 0

Fax.: (+49) 0 91 31 / 698 - 394

e-mail: [lukas.info@idexcorp.com](mailto:lukas.info@idexcorp.com)

[www.lukas.com](http://www.lukas.com)

MADE IN GERMANY